

A C B = 257 ± B.
A < X Z M U F = b.

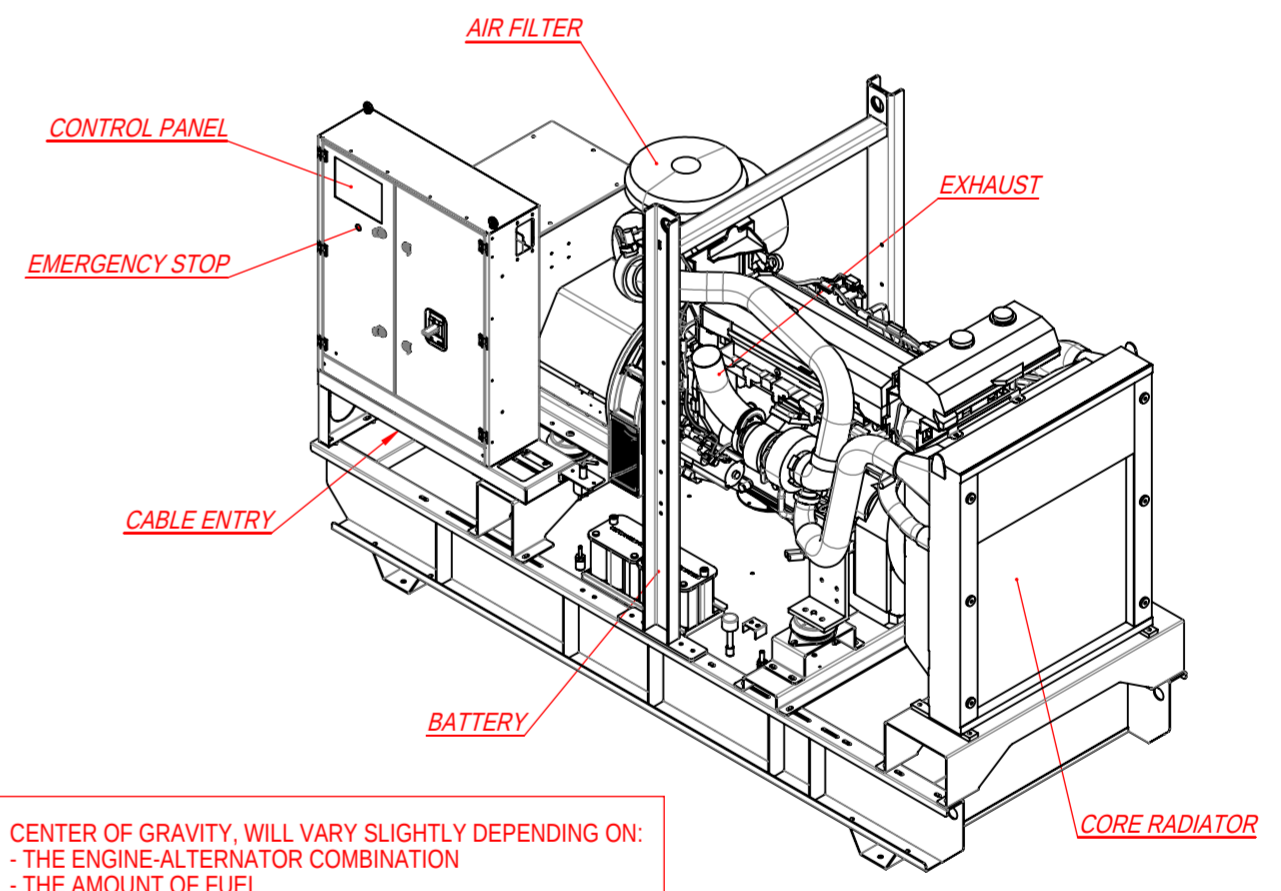

⚠ CENTER OF GRAVITY, WILL VARY SLIGHTLY DEPENDING ON:
- THE ENGINE-ALTERNATOR COMBINATION
- THE AMOUNT OF FUEL

ENGINE	CORE RADIATOR				EXHAUST			
	A	B	C	D	X	Y	Z	Ñ
VOLVO TAD732GE	753	960	211	698	864	1614	935	4" (101,6)
VOLVO TAD841GE	644	991	193	734	1298	1493	173	4" (101,6)
BAUDOUIN 6M16G275/5	729	960	90	950	874	1662	886	4" (101,6)

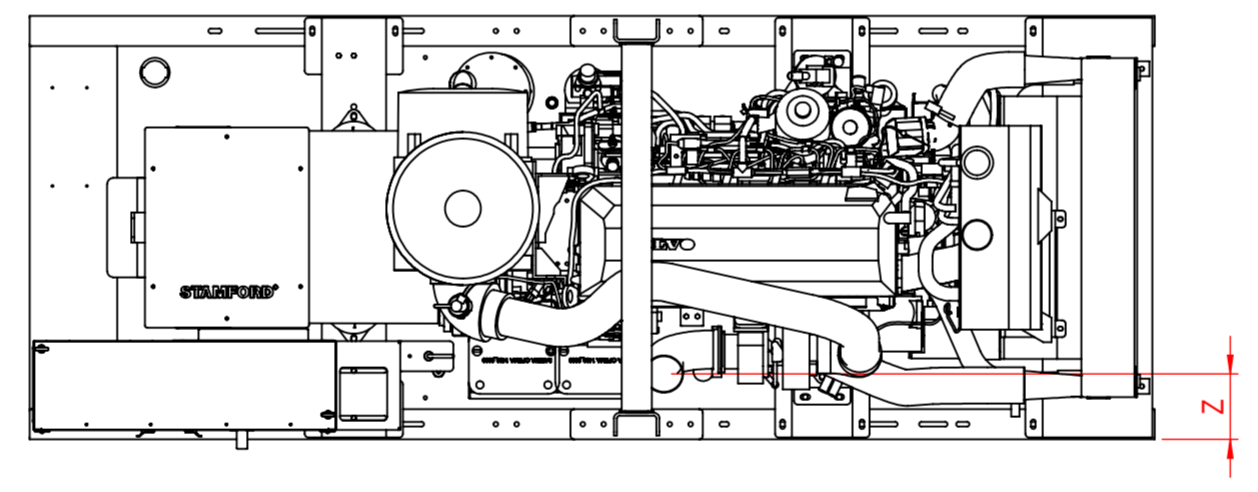
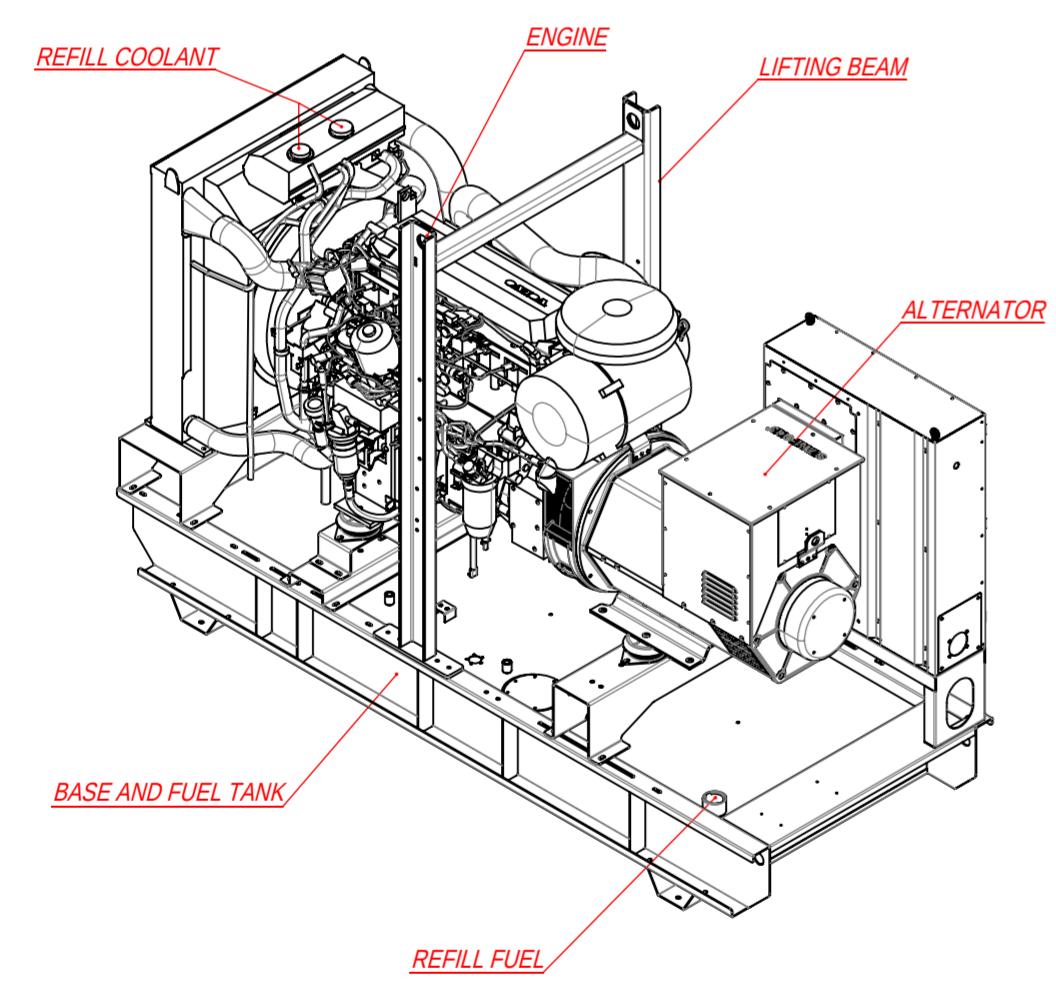
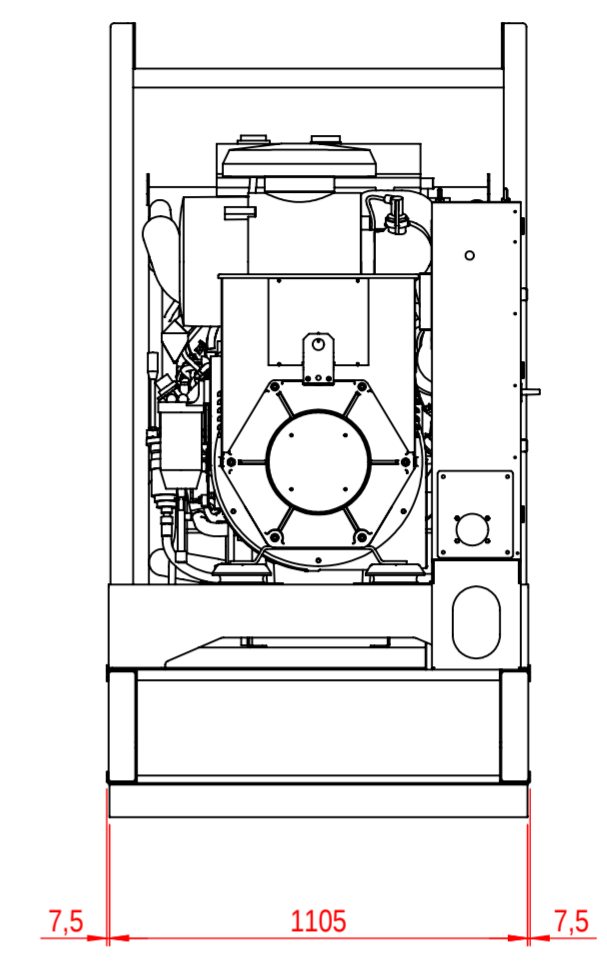
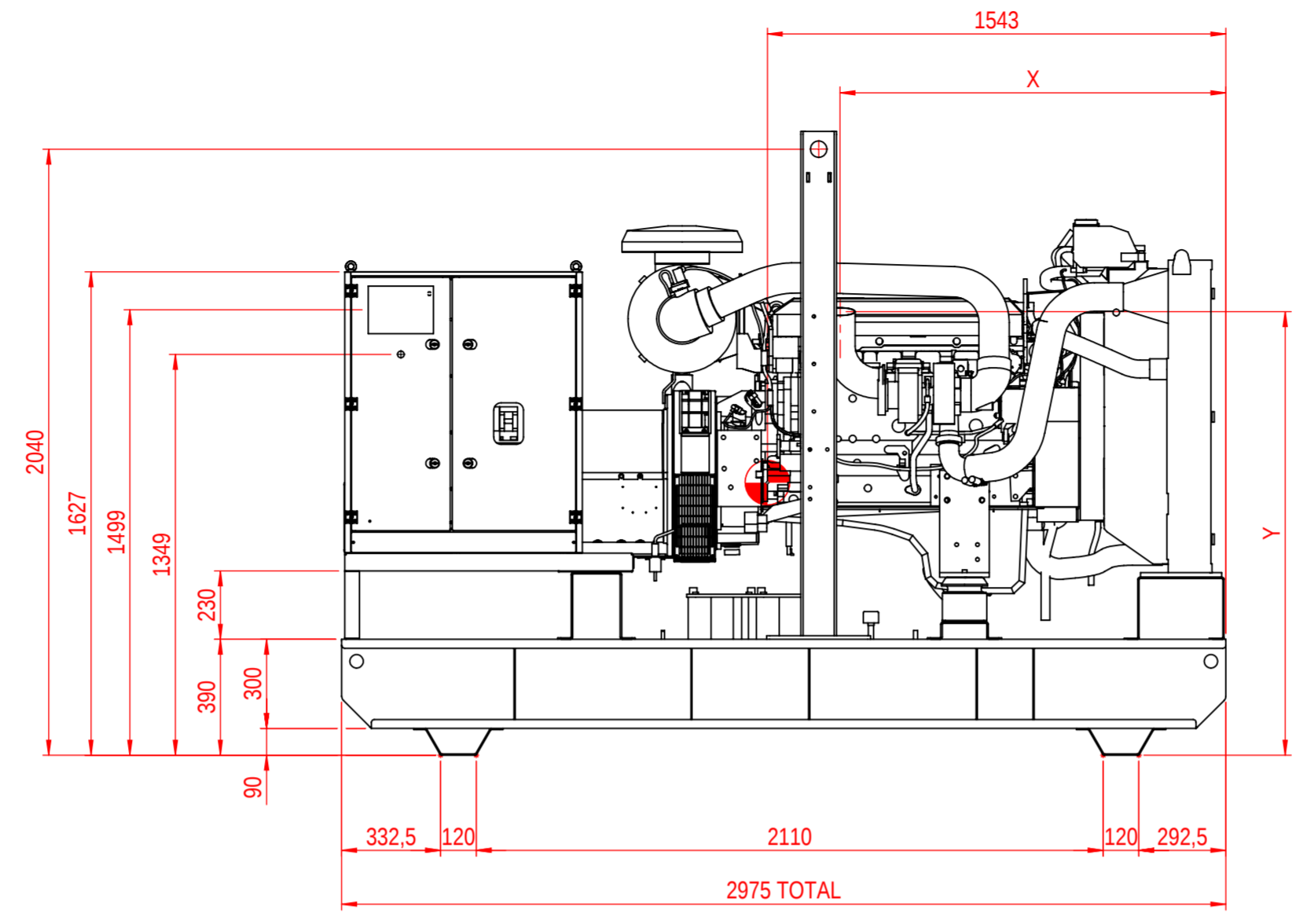
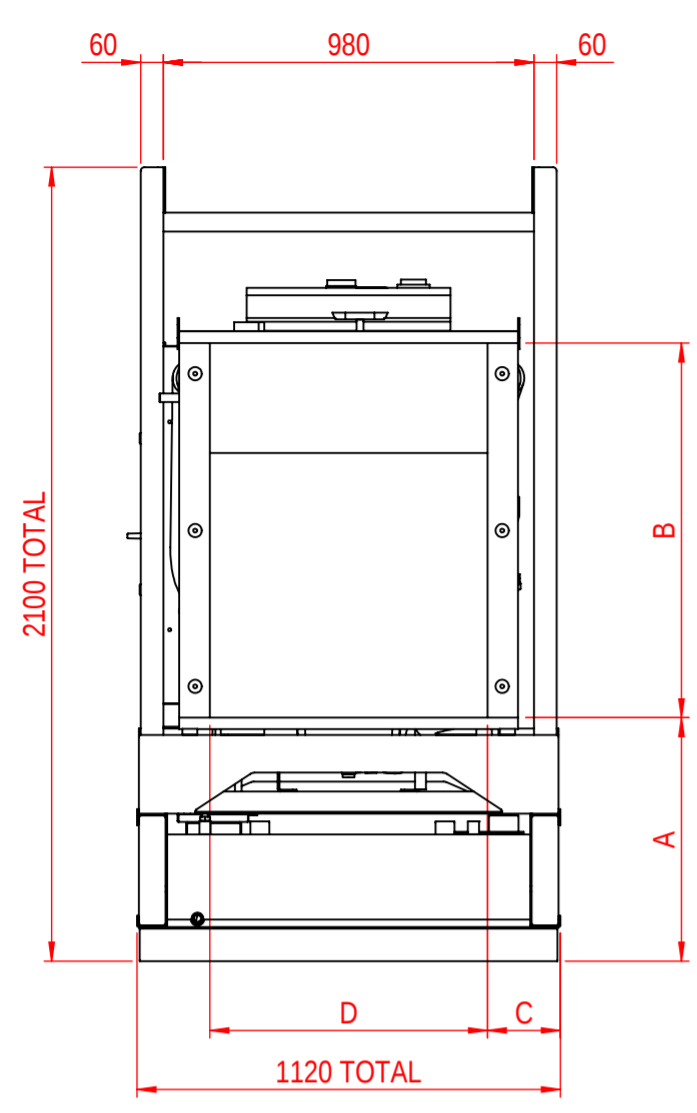
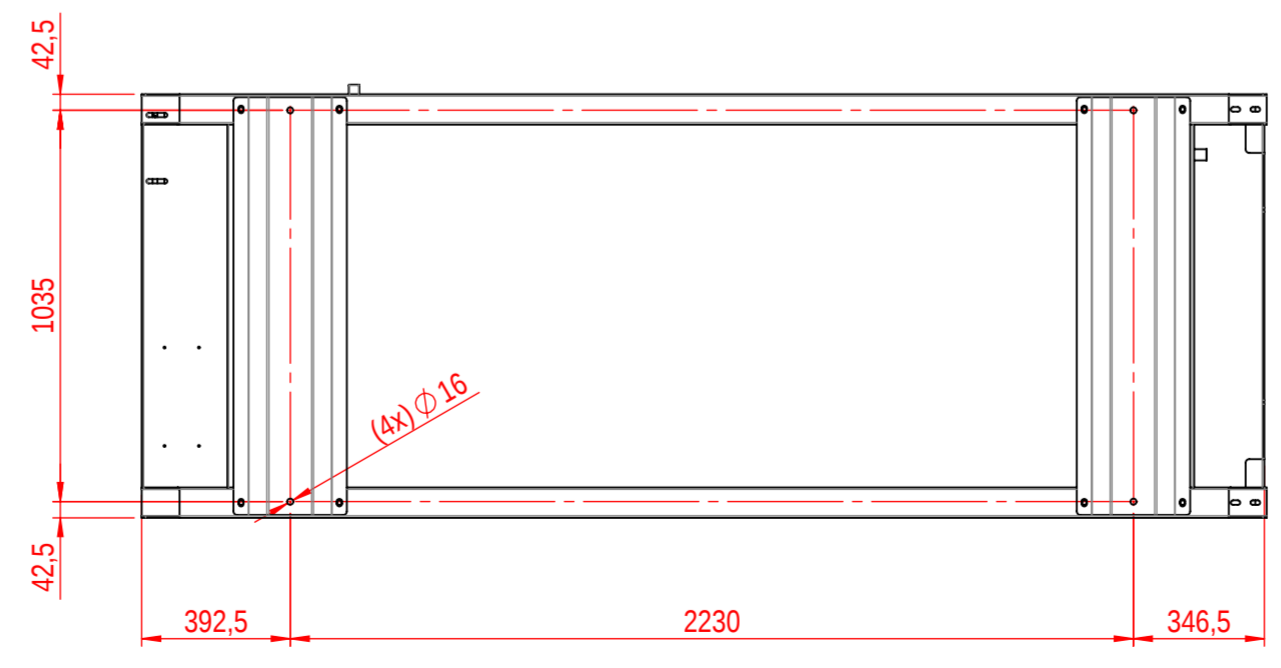

8 4l > 58C DC F. 8 0k b Vm	RSU OCE-CE	97 < 5 BUN	GCBEJ EDECE		BCFA 5G GC &+, IW
50FC 658C DC F. 5 0d f j Y X Vm	Ø VCF Ø E U Q	97 < 5 BUN	HEP EDECH		
A C B = 257 ± B DC F. A < X Z M U F = b	Ø VCF Ø E U Q	97 < 5 BUN	HEP EDECH		

ÖÖÖÖÜÖÖP ÖÖÖP ÜÖÖV Ö ÖWÜVÜÖÖŠ Š

T Å æ ~ ! ¨ Å Á { È
Ö ö ä ö & @ Å ^ ¸ ç ¸ A @ A ä @ Å / & @ * ^

J 9F G 6 B
J Y g e b

9C7 5 46
QWY.

FIGE

< C > 5.
Q.VYh

F/F