

DGH 12000 R

Portable Residential Range



⚡ POWER (PRP):
11 kVA / 11 kW

📡 FREQUENCY
50Hz

⚡ VOLTAGE
230V

📏 WEIGHT WITHOUT WHEELS:
121kg

📏 DIMENSIONS WITHOUT WHEELS:
L: 990 mm
W: 620 mm
H: 670 mm

Image for orientation purposes. Transport kit not included in the standard scope of delivery. Dagartech reserves the right to modify the data in this technical sheet without prior notice.

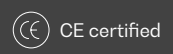
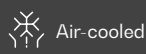
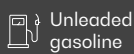

1. General technical data

General technical data

Engine	HONDA iGX800
Alternator	MECCALTE ES20F-200
Frequency	50Hz
Voltage	230V
Work regime (rpm)	3000
Type of regulation	Electronic (STR)
Power factor (cos φ)	1
Tank (l)	25
Type of start-up	Electric

Powers¹ (p.f. cos φ 1)

PRP (kVA / kW)	11 / 11
----------------	----------------

¹PRP: Prime Power according to ISO8528-1.

The transport kit is an option not included in the standard scope of supply of this equipment.

Directives and Regulations

ENVIRONMENTAL CONDITIONS STANDARD ISO 8528-1:2018: 25°C, 100kPa and 30% relative humidity:

- **Prime Power (PRP):** Data on electrical power available at variable load without limit of hours per year. An overload of 10% is allowed for 1h out of 12. According to ISO 8528-1:2018.
- **Emergency Standby Power (ESP):** Data on electrical capacity available at variable load in case of emergency according to ISO 8528-1:2018.

The DAGARTECH Generator bears the CE marking which includes the following directives:

- **2006/42/EC.** Machine Safety Directive.
- **EN ISO 8528-13:2016.** Part 13: Safety. Alternating current generators powered by reciprocating internal combustion engines.
- **2014/30/EU.** Electromagnetic Compatibility Directive.
- **2000/14/EC.** Noise Emissions Directive. Sound power levels evaluated in accordance with the procedure laid down in the directive.
- **Directive 2011/65/EU** on the restriction of the use of certain hazardous substances in electrical and electronic equipment (RoHS²).

230V - 50Hz (3000 rpm)

HONDA iGX800 | MECCALTE ES20F-200

2.1. General technical data of the engine

Make and model	HONDA iGX800
r.p.m.	3000
Continuous power - 3,000 rpm (kWm)	13,3
Max. net power - 3600 rpm (kWm)	13,3*
Type of regulation	Electronic (STR)
Fuel	Unleaded gasoline
No. of cylinders	2
Cylinder capacity (c.c.)	779
Compression ratio	9,1:1
Maximum torque (Nm)	54,5 (2500 r.p.m.)
Cooling system	Air-cooled
Start-up Method	Electric

4-STROKE-STROKE
PETROL ENGINE. AIR-COOLED.

* Gross power data for VANGUARD and BRIGGS-STRATTON engines.

2.2. Fuel

Type of fuel	Unleaded gasoline
Tank capacity	25

2.3. Consumption and autonomy

 75%
 100%

	Consumption (l/h)		Autonomy (h)	
	PRP	ESP	PRP	ESP
75%	N/A	-	N/A	-
100%	7,1	-	3,5	-

2.4. Lubrication system

Oil capacity (l)	1,8
Oil consumption (L/H)	N/A

3. Alternator specifications

3.1. General technical data of the alternator

Make and model	MECCALTE ES20F-200
No. of poles	2
Insulation class	H
Mechanical protection index	IP23
Voltage regulator	Brush + AVR
Power PRP 40°C (kVA)	11
No. of phases	1
Power factor (cos φ)	1



Standard regulations that the alternator meets:

Directives: 2006/42, 2006/95, 2004/108 and amendments thereto.

Complies with: EN 60034-1, CEI 2-3, IEC34-1, VDE 0530, BS 4999-5000, N.F. 51111.

2-pole

alternator, Brush + AVR.
 No maintenance required.

Winding protection by impregnation with tropicalised epoxy resin.

230V - 50Hz (3000 rpm)

HONDA iGX800 | MECCALTE ES20F-200

Our Residential range is equipped with Honda iGX engines, specially designed for automatic generators

iGX series engines are equipped with an electronic control unit with STR engine control, which stabilizes the frequency by $\pm 1\%$ at constant load, monitors and controls engine speed, ignition time and oil level.



It also incorporates warning and automatic shutdown due to oil level and automatic handle decompression system, as well as automatic choke that ensures remote starts.

STR.GOVERNOR

Electronically controlled



LESS NOISE AND VIBRATION

Reduction of noise levels up to -4dB(A)*



REDUCED FUEL CONSUMPTION

Fuel savings of 10 to 15%*

* Comparison made with the analogous model of the GX - Honda series.

And also...

The iGX series includes **automatic acceleration control**, which facilitates the use of the engine and prevents power and frequency drops.

As a result, engine vibrations are minimised, resulting in a longer life for the generating set.



DO YOU HAVE ANY QUESTIONS ABOUT THE PERFORMANCE OF THIS NEW ENGINE? DO YOU NEED ADVICE?

Get in touch with us.
We'll answer all your questions.

Write to us at
info@dagartech.com

Call us at:
+34 976 141 655



230V · 50Hz (3000 rpm)

HONDA iGX800 | MECCALTE ES20F-200

5. Standard scope of supply for the Residential range



1



2

What do you need?

Start and stop signal

You are looking for an automatic petrol generator, which can be started remotely (in the presence of volt-free signals - programming of its operation for a specific period of time or under specific conditions).

Network failure

You're looking for an automatic gasoline generator, which will launch in the event of a power failure.

STANDARD SCOPE OF DELIVERY

HONDA iGX800 Electric starter engine	☑	☑
Alternator MECCALTE ES20F-200 · Brush + AVR	☑	☑
Battery and charger	☑	☑
Compact electro-welded steel frame with anti-vibration dampers	☑	☑
Fuel tank of 25 litres capacity	☑	☑
Hour meter	☑	☑
Supply without engine lubrication oil	☑	☑
Engine oil protection	☑	☑
Fuel stopcock	☑	☑
Alternator thermal protection	☑	☑
Genset interconnection panel*	☑	☑

EXTERNAL PANEL



External panel - signal start and stop, equipped with DSE 3110 control module and load transfer contactor.



External panel - power failure, equipped with DSE 6020 MKII control module, power monitor and contactors.

Caption

☑ Included ☐ Optional ✗ Not available ⓘ Consult

* IP65 plastic box (IP64 die-cut).

230V - 50Hz (3000 rpm)

HONDA iGX800 | MECCALTE ES20F-200

5. Standard scope of supply for the Residential range



1

Start and stop signal



2

Network failure

What do you need?

EXTERNAL PANEL

Control module - Switchboard



External panel - signal start and stop, equipped with DSE 3110 control module and load transfer contactor.



External panel - power failure, equipped with DSE 6020 MKII control module, power monitor and contactors.

Battery and charger

Operating modes

STOP mode	☑	☑
MANUAL mode	☑	☑
TEST mode	☑	☑
AUTO mode	☑	☑

Module configuration options

PC	☑	☑
----	---	---

Generator readings

Generator voltage	☑	☑
Generator current (A)	✗	☑
Generator frequency	☑	☑
Generator load F-N (kW / kVA / kVAr)	✗	☑
Total generator load (kW / kVA / kVAr)	✗	☑
Average generator power factor	✗	☑
Accumulated generator load (kW, kVAh, kWh, kVAh)	✗	☑

Module configuration options

Network voltages (ph-N)	✗	☑
Network voltages (ph-ph)	✗	☑
Grid frequency	✗	☑
Network current (A)	✗	☐
Network load ph-N (kW / kVA / kVAr)	✗	☐
Total network load (kW / kVA / kVAr)	✗	☐

Caption

☑ Included ☐ Optional ✗ Not available ⓘ Consult

6. Available options



Would you like to customise the standard equipment of this generator to perfectly suit your needs?

Here are the options available in our line of portable residential generators.



KIT 1: Transport

With this kit composed of solid anti-puncture wheels, handles and support, you will be able to comfortably and easily transport and use it.

 WEIGHT WITH WHEELS:
126,5 kg

 DIMENSIONS WITH WHEELS:
L: 1026 mm
W: 756 mm
H: 789 mm

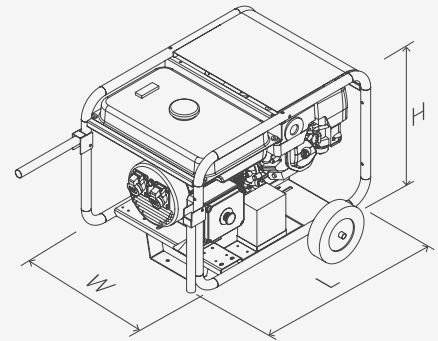

Do you need to add other features to this equipment? Can't find what you're looking for? Contact us and tell us what you need.





DAGARTECH®

CUSTOM ENERGY SOLUTIONS

info@dagartech.com

T +34 976 141 655



**CUSTOM
ENERGY
SOLUTIONS**

dagartech.com